

L I Q U I D F I L T R A T I O N S Y S T E M S



Rosedale[®] Mini-bag Series



**ROSEDALE[®]
PRODUCTS INC.**

Separation, Filtration, & Purification Technology.™



Rosedale® Mini-bag Series Model MF-1 & MF-2

An all-stainless steel Mini-bag Filter (MF-1) designed for service up to 3000 psi, this unit is ideal for protecting spray nozzles and other critical components. It provides a compact yet rugged solution for high-pressure liquid filtration.

The filter features a stainless steel wire mesh “bag” with 14 square inches of filtration area. Elements can be discarded when loaded with contaminants or cleaned and reused for extended service life. Flow travels from the inside to the outside of the element, trapping contaminants within the bag for efficient removal.

Its straight-through design eliminates elbows, sharp turns, and internal pockets that can cause pressure drop or collect sediment, making the housing easy to flush clean. Servicing is simple: loosen the knurled collar, shift the housing slightly out of line, remove the element, insert a new or cleaned bag, and return the unit to operation.

Sealing is achieved with a special Teflon-encapsulated Viton O-ring, which can be tightened securely—typically by hand—using the knurled collar.

SPECIFICATIONS

- Pressure rating: 3000 psi (MF-1)
- Differential pressure rating: 25 psi
- Port sizes: 3/8 inch NPT
- Micron retention ratings (absolute): 25, 50, 75, 100, 125, and 150



Speak with a product representative today.

800.821.5373



Model MF-1 & MF-2

Rosedale® Mini-bag Series

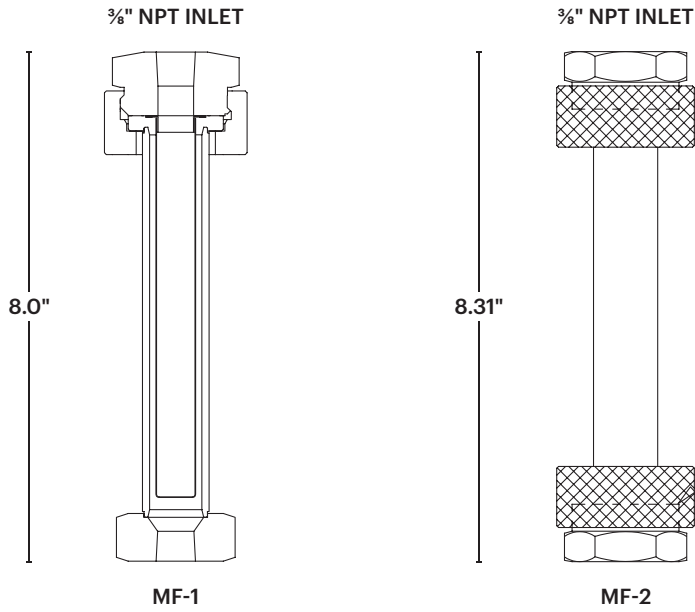

FLOW CAPACITIES

- GPM at 2 psi (.14 bar) pressure drop (micron ratings)

VISCOSITY (SSU/CST)	150 MIC	75 MIC	50 MIC	25 MIC
100/20.5	6	6	6	6
250/55	6	6	5.3	4
1000/250	4.5	4	3.1	2
1500/325	3.5	3.5	2.3	1.5



Rosedale® MB-100 Wire Mesh Bag



Rosedale® Model MF-1

Note: MF-1 filter housings and element bags are sold separately.



Rosedale® Model MBII

Rosedale also offers a comparable compact bag filter, the model MBII (300 psi), featuring a two-bolt swing bolt closure. It is designed to accept Nylon Monofilament (NMO) MBII elements and utilizes TEV seals for reliable performance. The MBII is available with an optional stainless steel mounting stand and is well suited for small, low-flow applications.

Accessories



**Rosedale® Model MBII
Mounting Stand Kit**
Item#: C28865.40.2
Part#: STAND ASSY MINI BAG II 304



Rosedale® Model MBII Bag & Strainer
Item#: 11-19565
Part#: BASKET MINI BAG II 1/8" PER 316

Rosedale® Model MBII Seal Options
Cover Item#: 11-19571
Cover Part#: O-RING, TEV MBII COVER
Basket Item#: 11-19575
Basket Part#: O-RING, TEV MBII BASKET
Mesh Item#: 11-20726
Mesh Part#: O-RING, TEV MBII MESH

Speak with a product representative today.

800.821.5373

Note: MBII - NMO Mesh comes with Buna Seal Standard.

Model MBII

Rosedale® Mini-bag Series

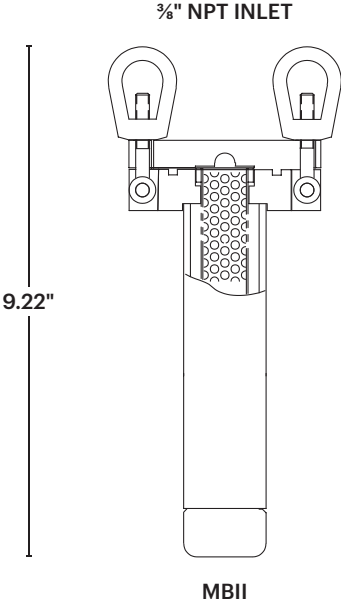

Note: Optional mounting stand kit shown. MBII filter housings, strainer, and element bags are sold separately. Consult factory for other customized options.



Rosedale® Model MF-1



Filter Housing & Bags: How to Order.

FILTER HOUSING PART NUMBER (EXAMPLE: MF-1)

ELEMENT BAG PART NUMBER (EXAMPLE: MB-25)

A

HOUSING
TYPE

B

BAG
TYPE

A	ROSEDALE® MIN-BAG FILTER HOUSING	ITEM NUMBER	PART NUMBER
	MINI-BAG	MF-1	MF-1 MINI-BAG FILTER

B	MINI-BAG ELEMENT BAG (MICRON RATING)	ITEM NUMBER	PART NUMBER
	25 MICRON (ABSOLUTE)	11-4188	MB-25
	50 MICRON (ABSOLUTE)	11-4189	MB-50
	75 MICRON (ABSOLUTE)	11-4190	MB-72
	100 MICRON (ABSOLUTE)	11-4214	MB-100
	125 MICRON (ABSOLUTE)	11-4235	MB-125
	150 MICRON (ABSOLUTE)	11-4191	MB-150
	200 MICRON (ABSOLUTE)	11-7347	MB-200
	250 MICRON (ABSOLUTE)	11-7631	MB-250
	420 MICRON (ABSOLUTE)	11-5172	MB-420
	840 MICRON (ABSOLUTE)	11-5172	MB-840

Speak with a product representative today.

800.821.5373

Note:
Model MF-2 with 2 collars, to be removed from rigid piping, is also available.
Consult factory.

NEW

Rosedale® Model MBII



Filter Housing & Bags: How to Order.

FILTER HOUSING PART NUMBER (EXAMPLE: MINI BAG II 3/8" NPT 300 #316)

ELEMENT BAG PART NUMBER (EXAMPLE: MBII-5MICRON-NMO)

A

HOUSING
TYPE

B

BAG
TYPE

A	ROSEDALE® MINI-BAG II FILTER HOUSING	ITEM NUMBER	PART NUMBER
	MINI-BAG II	11-19552	MINI BAG II 3/8" NPT 300 #316

B	MINI-BAG II ELEMENT BAG (MICRON RATING)	ITEM NUMBER	PART NUMBER
	5 MICRON (ABSOLUTE)	11-21263	MBII-5MICRON-NMO
	10 MICRON (ABSOLUTE)	11-21264	MBII-10MICRON-NMO
	25 MICRON (ABSOLUTE)	11-23300	MBII-25MICRON-NMO
	35 MICRON (ABSOLUTE)	11-21269	MBII-25MICRON-NMO
	55 MICRON (ABSOLUTE)	11-23310	MBII-55MICRON-NMO
	100 MICRON (ABSOLUTE)	11-21262	MBII-100MICRON-NMO
	150 MICRON (ABSOLUTE)	11-23311	MBII-150MICRON-NMO
	200 MICRON (ABSOLUTE)	11-23312	MBII-200MICRON-NMO
	250 MICRON (ABSOLUTE)	11-23313	MBII-250MICRON-NMO
	300 MICRON (ABSOLUTE)	11-23314	MBII-300MICRON-NMO
	400 MICRON (ABSOLUTE)	11-23315	MBII-400MICRON-NMO
	600 MICRON (ABSOLUTE)	11-23316	MBII-600MICRON-NMO
	800 MICRON (ABSOLUTE)	11-23317	MBII-800MICRON-NMO

Note: Optional mounting stand kit shown. MBII filter housings, strainer, and element bags are sold separately. Consult factory for other customized options.

**Welcome
to the future of
liquid filtration
technology.**



**ROSEDALE[®]
PRODUCTS INC.**

Separation, Filtration, & Purification Technology.™



Rosedale Products, Inc. is a leading technology developer in the field of liquid filtration systems and waste minimization products for customers around the world. With more than 50 years of experience, Rosedale offers an exceptional product line that includes high-performance filtration solutions for multiple industries. Rosedale technicians help customers find the best, most cost-effective approaches to their filtration needs.

Rosedale's product line sets the industry standard in versatility and reliability and includes bag and cartridge filters, basket strainers, automatic back washing filters, filter cartridges, and many special application products. Together with ongoing consulting, troubleshooting, and support from our team of in-house experts, Rosedale provides comprehensive solutions for every critical industry filtration need. Rosedale manufactures industrial filtration products for virtually any industry where liquid and gas flows are present.

We have a vast product line that suits many needs, as well as the flexibility to customize standard products. Our sales staff has knowledge of many industrial practices, giving customers the confidence that their filter solution is the best available for their specific need. Our most popular products are bag filters, pleated cartridge filters, and basket strainers.

Speak with a product representative today. 800.821.5373.
For product details please visit [RosedaleProducts.com](https://www.RosedaleProducts.com).



We're committed to your vision with in-stock and made-to-order designs.

Single Bag Housings
Multi-Bag Housings
Polypropylene Housings
Indicating Filter
Centrifugal Separators
Backwashing Systems
Coolant Filter Systems
High Capacity Elements
Filter Bags



Contact us today for
more information.
800.821.5373
RosedaleProducts.com



**ROSEDALE[®]
PRODUCTS INC.**

Separation, Filtration, & Purification Technology.™



Rosedale Products Inc.
3730 W. Liberty Rd. Ann Arbor, MI 48103
Email: Filters@RosedaleProducts.com
Phone: 734.665.8201 • Fax: 734.665.2214
©2025 Rosedale Products Inc.